

Model PRV-1 Pressure Reducing Valve 2 thru 8 Inch (DN50 thru DN200), 250 psi (17,2 bar) Pilot Operated, Globe and Angle Body Styles

General Description

The 2 thru 8 inch (DN50 thru DN200) Model PRV-1 Pressure Reducing Valves are factory assembled and fully trimmed valve arrangements for pressure control. They are used on water filled pipe where it is necessary to reduce a higher inlet pressure to a lower delivery pressure under static and/or residual flowing conditions. The PRV-1 is intended to automatically maintain the outlet "set pressure" (static and residual) within a close range, regardless of fluctuations in the higher pressure inlet line or varying flow rates.

The PRV-1 is provided with a factory outlet "set pressure" of 125 psi (8,6 bar); however it may be field set to a nominal outlet "set pressure" of 80 to 150 psi (5,5 to 10,3 bar).

Typical applications are as follows:

- Within the main header (Ref. Figure 1) supplying wet pipe, dry pipe, deluge, or preaction system risers, and/or a standpipe system supplying hose connections.
- As part of a sectional floor control assembly (Ref. Figure 2) supplying sprinkler systems, and/or hose stations.

Features are as follows:

- Can be installed in any orientation.
- Eliminates any required bleeding of trapped air from the diaphragm chamber during installation.
- Globe or angle pattern.
- Accurate pressure control.
- Standard nylon coated internal and external.

(continued)

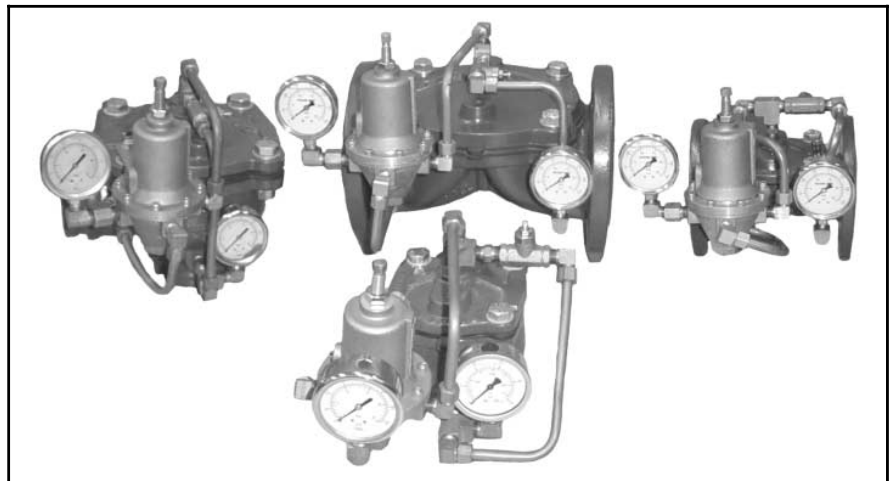

NORTH AMERICA Available Body Styles, End Connections & Sizes						
Body Style	End Connection	Nominal Valve Size				
		2 Inch (DN50)	3 Inch (DN80)	4 Inch (DN100)	6 Inch (DN150)	8 Inch (DN200)
Globe	Thread x Thread	●	N/A	N/A	N/A	N/A
	Groove x Groove	●	●	●	●	N/A
	Flange x Flange	N/A	N/A	●	●	●

● = Available N/A = Not Available

SOUTH AMERICA, CENTRAL AMERICA & EASTERN HEMISPHERE Available Body Styles, End Connections & Sizes						
Body Style	End Connection	Nominal Valve Size				
		2 Inch (DN50)	3 Inch (DN80)	4 Inch (DN100)	6 Inch (DN150)	8 Inch (DN200)
Globe	Thread x Thread	●	●	N/A	N/A	N/A
	Groove x Groove	●	●	●	●	N/A
	Flange x Flange	N/A	●	●	●	●
Angle	Thread x Thread	●	●	N/A	N/A	N/A
	Groove x Groove	●	●	●	●	N/A
	Flange x Flange	N/A	●	●	●	N/A

● = Available N/A = Not Available

- One piece, one moving part diaphragm.
- In-line service.
- One pilot valve sub-assembly provides for any outlet "set pressure", i.e., 80 to 150 psi (5,5 to 10,3 bar).

WARNING

The Model PRV-1 Pressure Reducing Valves described herein must be installed and maintained in compliance with this document, as well as with the applicable standards of the National Fire Protection Association, in addition to the standards of any other authorities having jurisdiction. **Failure to do so may impair the performance of these devices.**

The owner is responsible for maintaining their fire protection system and devices in proper operating condition. The installing contractor or sprinkler manufacturer should be contacted with any questions.

Due to the flow regulating characteristic of this device, its impact on system hydraulics should be carefully considered, especially when retrofitted into existing systems.

Downstream pressure adjustment is only to be performed by experienced personnel who understand the impact of adjusting the downstream pressure and who take full responsibility of the readjustment from the factory setting. The Pilot Valve is provided with a Tamper Cap, which upon removal for purposes of downstream adjustment will provide an indication that the PRV-1 may have been altered from its factory setting.

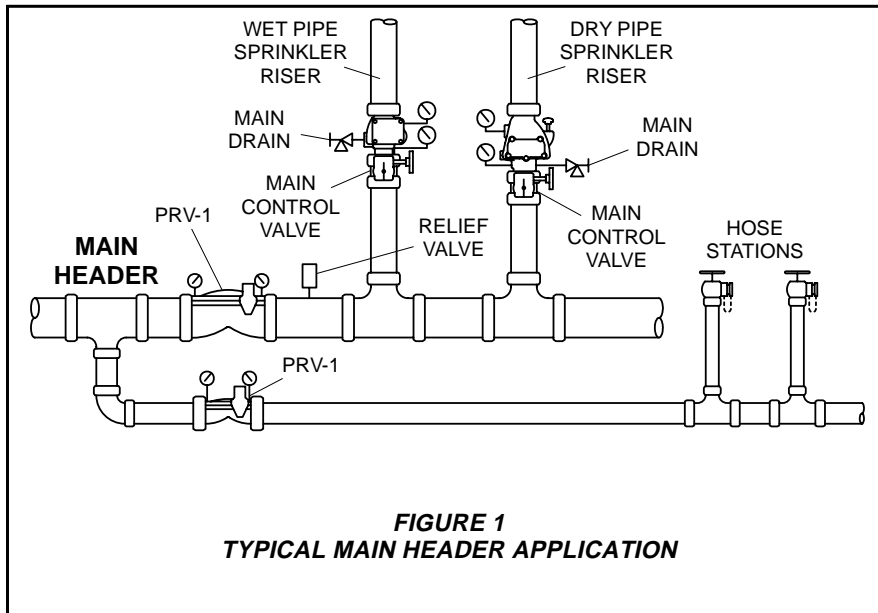

**FIGURE 1
TYPICAL MAIN HEADER APPLICATION**

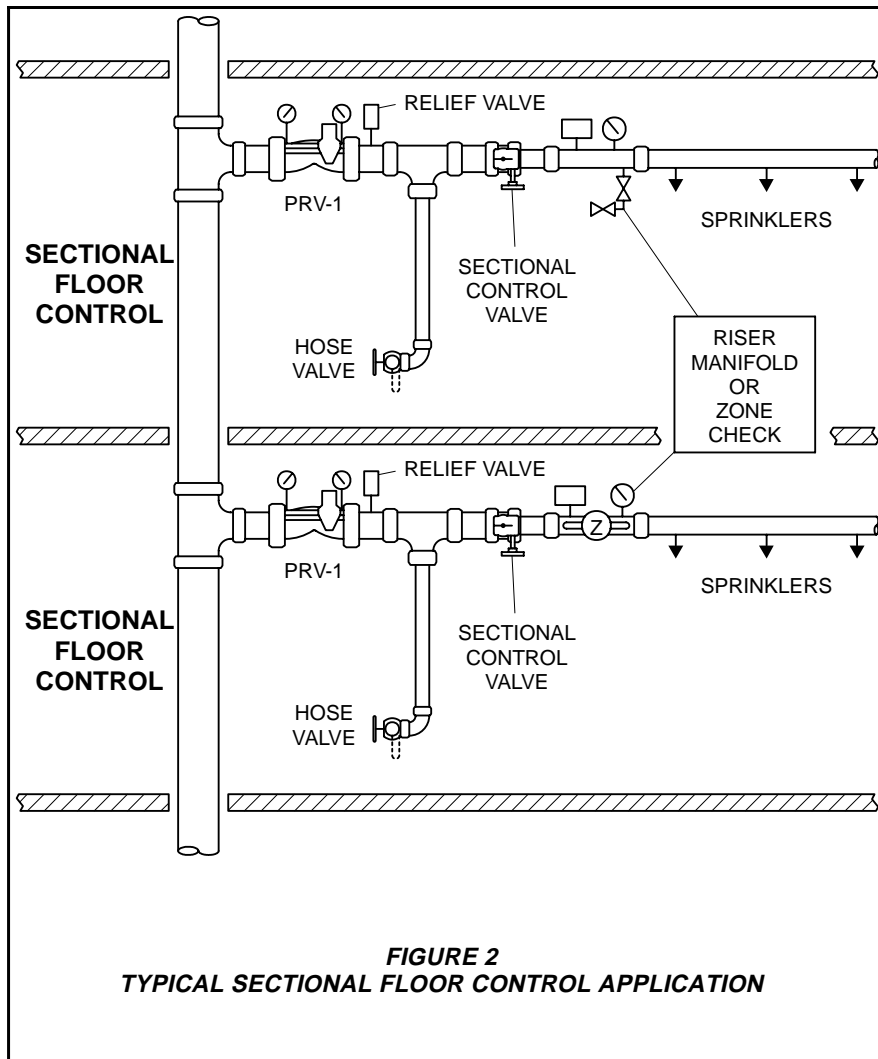

**FIGURE 2
TYPICAL SECTIONAL FLOOR CONTROL APPLICATION**

VALVE PARTS			
NO.	DESCRIPTION	QTY.	Refer to Kit
1	Valve Body	1	NR
2	Diaphragm	1	(a)
3	Handhole Cover	1	NR
4	Flat Washer,		
	2 Inch Valve, M12	4	CH
	3 & 4 Inch Valves, M16	4	CH
	6 & 8 Inch Valves, M16	8	CH
5	Hex Bolt,		
	2 Inch Valve, M12 x 35	4	CH
	3 & 4 Inch Valves,		
	M16 x 55	4	CH
	6 Inch Valve, M16 x 45	8	CH
	8 Inch Valve, M16 x 55	8	CH
6	Hex Nut, M16,		
	4 Inch Valve Only	4	CH
7	Pilot Valve	1	(b)
8	Water Pressure Gauge	2	(c)
9	Strainer	1	(d)
10	Pressure Sensor Insert	1	(e)
11	Tubing and Fittings	1	(f)

REPLACEMENT PARTS		
NO.	DESCRIPTION	P/N
(a)	Diaphragm, Fits Either Body Style, Includes Item 2 only:	
	2 Inch Valves	92-570-2-011
	3 Inch Valves	92-570-2-012
	4 Inch Valves	92-570-2-013
	6 Inch Valves	92-570-2-014
	8 Inch Valves	92-570-2-015
(b)	Pilot Valve	92-570-2-200
(c)	Water Pressure Gauge	92-570-2-201
(d)	Strainer:	
	2, 3, & 4 Inch Valves	92-570-2-202
	6 & 8 Inch Valves	92-570-2-209
(e)	Pressure Sensor Insert:	
	2 Inch Valve	92-570-2-203
	3 Inch Valve	92-570-2-204
	4 Inch Valve	92-570-2-205
	6 Inch Valve	92-570-2-206
	8 Inch Valve	92-570-2-207
(f)	Tubing and Fitting Kit, Excludes Items 7, 8, 9, and 10	
	Globe Style Valve:	
	2 Inch Valve	92-570-3-001
	3 Inch Valve	92-570-3-002
	4 Inch Valve	92-570-3-003
	6 Inch Valve	92-570-3-004
	8 Inch Valve	92-570-3-005
	Angle Style Valve:	
	2 Inch Valve	92-571-3-001
	3 Inch Valve	92-571-3-002
	4 Inch Valve	92-571-3-003
	6 Inch Valve	92-571-3-004

NOTES:

- NR - Not Replaceable
- CH - Common Hardware

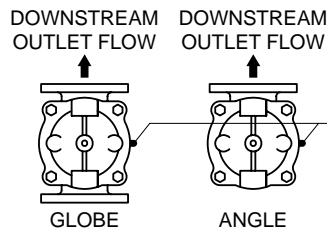

DIAPHRAGM TAB IS ORIENTED PERPENDICULAR TO OUTLET FLOW

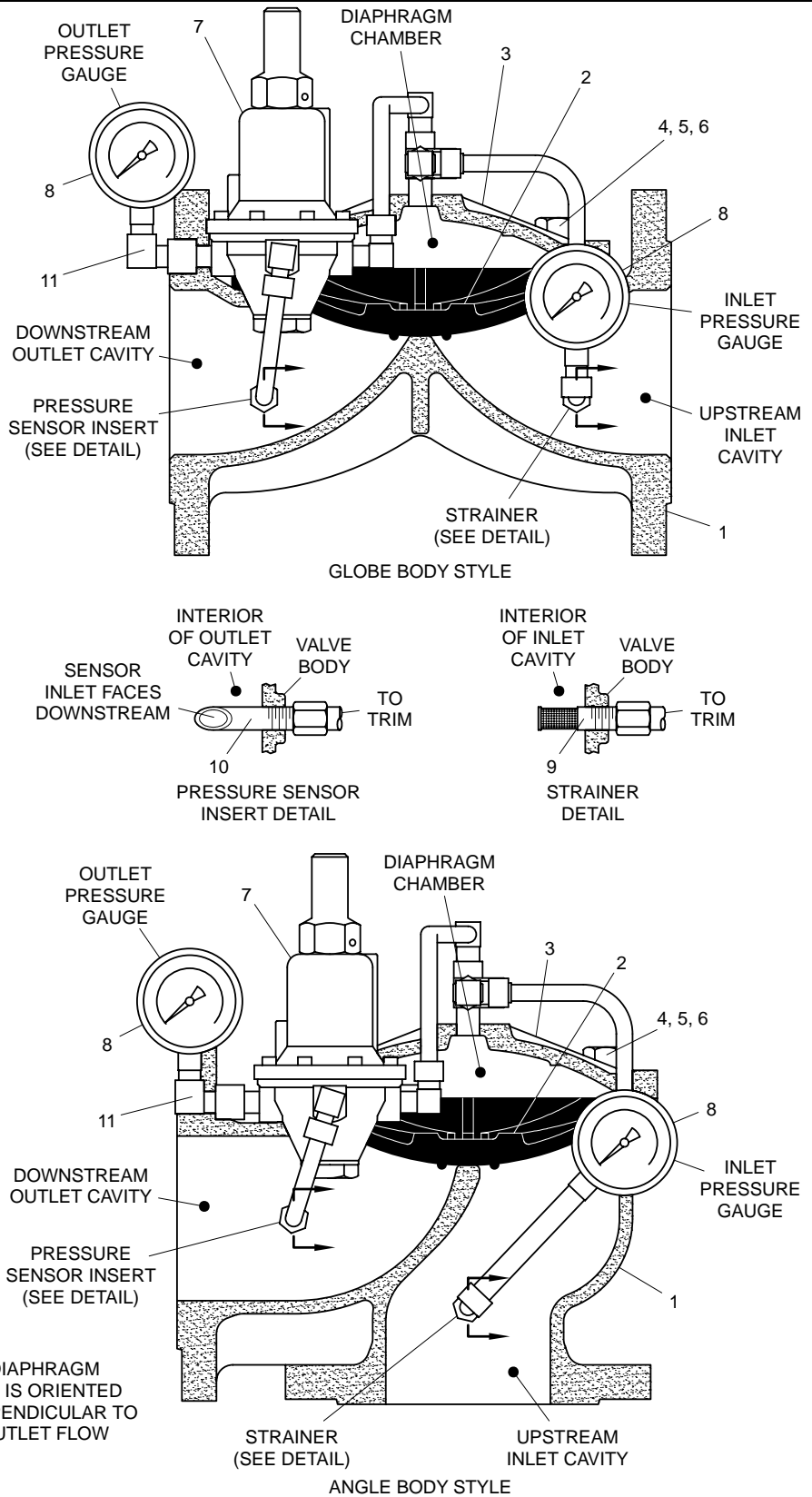

FIGURE 3
MODEL PRV-1 PRESSURE REDUCING VALVE
— ASSEMBLY —

Technical Data

Approvals:

UL Listed. FM Approved.

The UL Listing is based on

- Installation requirements referenced in the Standard for Installation of Sprinkler Systems, NFPA 13, or the Standard for Installation of Standpipe and Hose Valves, NFPA 14, as applicable.
- Inspection, testing, and maintenance requirements referenced in the Standard for Inspection, Testing, and Maintenance of Water-Based Fire Protection Systems, NFPA 25.
- The Model PRV-1 being field set to provide the required outlet pressures and flows for the given application.
- The Model PRV-1 being tested after installation in accordance with NFPA 13 and/or NFPA 14 as applicable.
- The Model PRV-1 being tested periodically thereafter in accordance with NFPA 25.

Maximum Inlet Pressure:

250 psi (17,2 bar)

Factory Outlet “Set Pressure”:

125 psi (8,6 bar)

Field Outlet “Set Pressure” Range:

80 to 150 psi (5,5 to 10,3 bar)

Pressure Loss Below “Set Pressure”

Refer to Graphs A thru E. (These graphs are a requirement of UL and should be used as reference only.)

Rated Flowing Range:

2 inch (DN50): 0 to 250 GPM (0 to 946 LPM)

3 inch (DN80): 0 to 550 GPM (0 to 2080 LPM)

4 inch (DN100): 0 to 1000 GPM (0 to 3785 LPM)

6 inch (DN150): 0 to 2200 GPM (0 to 8325 LPM)

8 inch (DN200): 0 to 4000 GPM (0 to 15140 LPM)

End Connections:

Threaded end connections are available NPT threaded or threaded per ISO 7/1. Flanged end connections are available drilled per Table A.

Grooved end connections are per industry standard groove specifications.

Construction (Ref. Figure 3):

Body. Rilsan* blue coated ductile iron per ASTM A536-77, Grade 65-45-12.

Handhole Cover. Rilsan* blue coated ductile iron per ASTM A536-77, Grade 65-45-12.

Diaphragm. Nylon fabric reinforced, natural rubber per ASTM D2000.

Diaphragm Cover Fasteners. Galvanized carbon steel.

Pilot Valve. Brass and stainless steel with nylon fabric reinforced, natural rubber per ASTM D2000 diaphragm.

Strainer. Brass and stainless steel.

Pressure Gauges. 2-1/2 inch (65 mm) diameter, stainless steel case, 0 to 350 psi (25 bar).

Tube, Fittings, and Needle Valve. Copper, brass, and stainless steel.

*Rilsan is a registered trademark of ATOFINA Chemicals, Inc. (The Rilsan coating is a polyamide (Nylon 11) coating.)

Nominal Valve Size	Flange Drilling Specification														
	Nominal Dimensions in Inches and (mm)														
	ANSI B16.1 ¹ (Class 125)			ISO 7005-2 (PN10) ²			ISO 7005-2 (PN16) ³			JIS B 2210 (10K)			AS 2129 (Table E)		
	Dim. A	Dim. B	Qty. N	Dim. A	Dim. B	Qty. N	Dim. A	Dim. B	Qty. N	Dim. A	Dim. B	Qty. N	Dim. A	Dim. B	Qty. N
3 Inch (DN80)	6.00 (152,4)	0.75 (19,0)	4	USE ISO 7005-2 (PN16)			6.30 (160,0)	0.75 (19,0)	8	5.90 (150,0)	0.59 (15,0)	8	5.75 (146,0)	0.71 (18,0)	4
4 Inch (DN100)	7.50 (190,5)	0.75 (19,0)	8				7.09 (180,0)	0.75 (19,0)	8	6.89 (175,0)	0.59 (15,0)	8	7.00 (178,0)	0.71 (18,0)	8
6 Inch (DN150)	9.50 (241,3)	0.88 (22,2)	8				9.45 (240,0)	0.91 (23,0)	8	9.45 (240,0)	0.75 (19,0)	8	9.25 (235,0)	0.87 (22,0)	8
8 Inch (DN200)	11.75 (298,5)	0.88 (22,2)	8	11.61 (295,0)	0.91 (23,0)	8	11.61 (295,0)	0.91 (23,0)	12	11.42 (290,0)	0.75 (19,0)	12	11.50 (292,0)	0.87 (22,0)	8

¹ Same drilling as for ANSI B16.5 (Class 150) and ANSI B16.42 (Class 150).
² Same drilling as for BS 4504 Section 3.2 (PN10) and DIN 2532 (PN10).
³ Same drilling as for BS 4504 Section 3.2 (PN16) and DIN 2532 (PN16).

Dim. A Bolt Circle Diameter

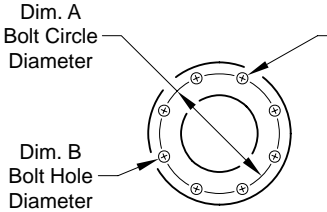

Dim. B Bolt Hole Diameter

Qty. N Number of Bolt Holes

TABLE A
DIMENSIONAL SPECIFICATION FOR SELECTION OF FLANGE DRILLING

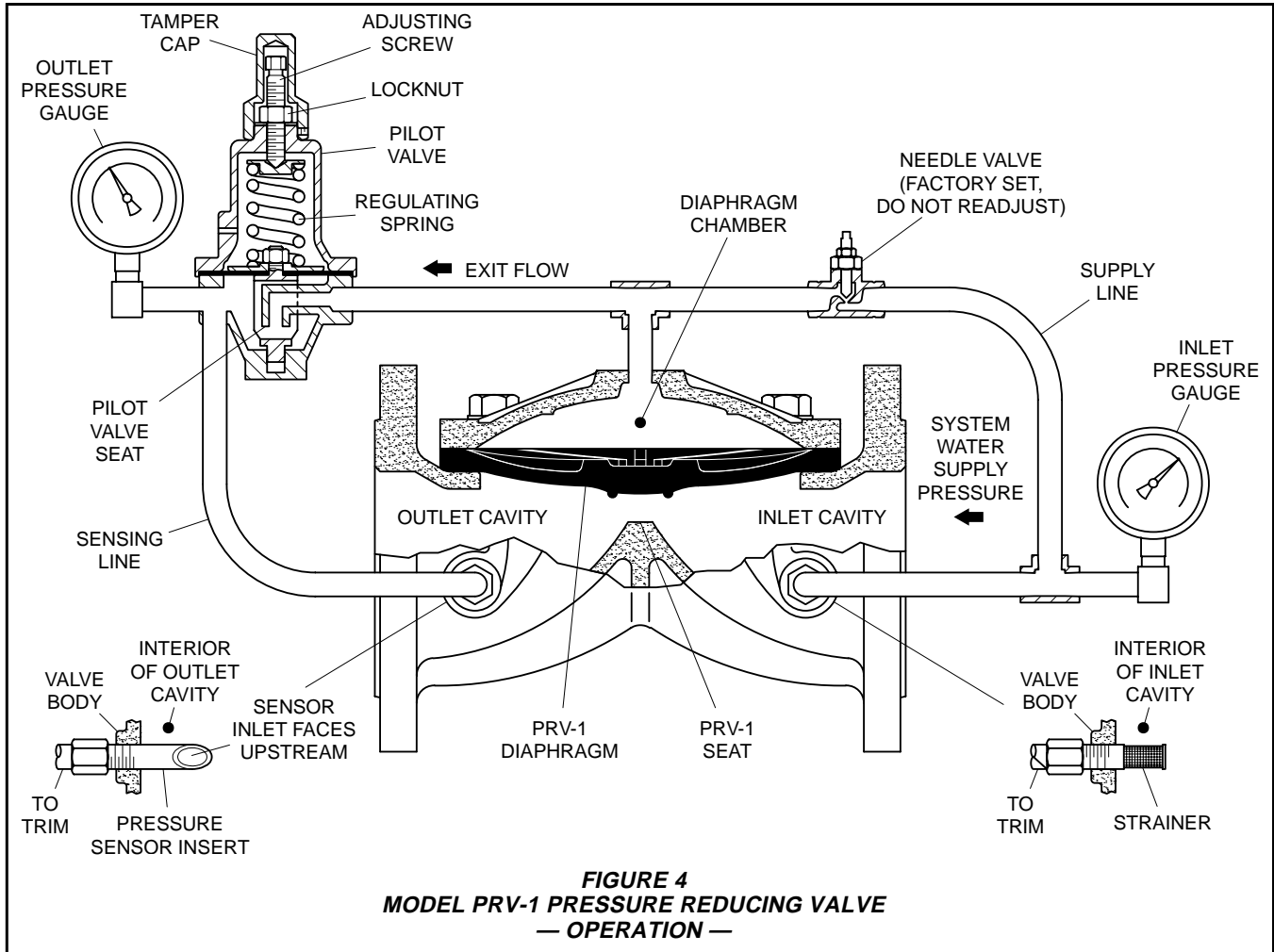

Operation

With reference to Figure 4, the system water supply pressure from the inlet cavity of the PRV-1 enters the Diaphragm Chamber through a Strainer and Needle Valve. The factory set Needle Valve provides the required orifice size for the supply line to the Diaphragm Chamber to optimize performance.

Exit flow from the Diaphragm Chamber through the Pilot Valve is controlled by a regulating spring that is factory set, and subsequently field adjustable, to the desired downstream “set pressure” that is to be maintained. A sensing line connects the outlet of the Pilot Valve to the system piping downstream of the PRV-1 via the Pressure Sensor Insert in the outlet cavity.

When the downstream pressure rises above the “set pressure” of the spring, exit flow from the Diaphragm Chamber through the Pilot Valve to the PRV-1 outlet cavity is stopped and pressure increases in the Diaphragm Chamber. When downstream pressure falls be-

low the “set pressure” of the spring, exit flow from the Diaphragm Chamber through the Pilot Valve to the PRV-1 outlet cavity resumes and pressure in the Diaphragm Chamber decreases.

The regulated flow through the Pilot Valve decreases and increases the pressure in the diaphragm chamber to sufficiently open and close the PRV-1, as required, to regulate the downstream “set pressure”.

The operation sequence is as follows:

- When there is no flow demand downstream of the PRV-1, the PRV-1 Seat is closed and the Pilot Valve Seat is closed. With the Pilot Valve Seat closed, pressure is trapped in the Diaphragm Chamber to seat the Diaphragm and the PRV-1 remains closed.
- When there is a flow demand downstream of the PRV-1 and the PRV-1 outlet pressure drops below the “set pressure”, the Pilot Valve Seat opens to relieve pressure from the Diaphragm Chamber allowing the PRV-1 to open.
- As the flow demand continues downstream of the PRV-1 and the “set pressure” is met, the Pilot Valve Seat closes. As the Pilot Valve Seat closes to reduce the opening, pressure is trapped in the Diaphragm Chamber at a point that allows the Diaphragm to remain lifted from the PRV-1 Seat to retain the downstream “set pressure”.
- Should the downstream pressure start to fall below the “set pressure”, the Pilot Valve Seat re-opens to allow for a decrease in pressure in the Diaphragm Chamber to allow the PRV-1 to open further and then once again establish the downstream “set pressure”.
- When the downstream pressure is at or above the “set pressure” and assuming there is a flow demand downstream of the PRV-1, the Pilot Valve Seat is closed to trap a sufficient pressure in the Diaphragm Chamber to allow the PRV-1 to remain open to provide the “set pressure”.

Design Considerations

The following items must be considered and applied accordingly for an installation that will be using the Model PRV-1 Pressure Reducing Valve:

- The PRV-1 may be installed vertically or horizontally and in any orientation without affecting its operating efficiency. When planning the positioning of the PRV-1, it is recommended that consideration be given to the viewing of the pressure gauges. Consideration should also be given to positioning the PRV-1 so that the diaphragm cover is facing up. With the cover facing up, internal access is more easily achieved.
- The PRV-1 must be in an area that is easily accessible for maintenance purposes, not subject to freezing temperatures, and not subject to physical damage.
- The valve is designed for fresh water service. When corrosive atmospheres and/or contaminated water supplies are present, it is the owner's responsibility to verify compatibility with the pressure reducing valve, pilot valve, and trim.
- The difference between the water supply pressure and the desired outlet (downstream) pressure must be 50 psi (3,4 bar) or greater to maintain accurate control of the discharging pressure over the full rated flowing range.
- Cavitation may occur when the inlet pressure is greater than twice the "set pressure". For this case, the pressure should be reduced in two steps by using two PRV-1's in series.
- When reducing pressure for a sprinkler system, a relief valve of not less than 1/2 inch (DN15) in size shall be located downstream of the PRV-1. The relief valve shall be set at 10 psi (0,7 bar) higher than the maximum expected outlet pressure of the PRV-1. **NOTE: FM Approval is based on the use the 1/2 inch, Watts Regulator, Series 530C Pressure Relief Valve.**
- When reducing pressure for a sprinkler system, a listed indicating valve shall be provided on the inlet side of the PRV-1.
- When reducing pressure for a sprinkler system, means shall be provided downstream of the PRV-1 to facilitate a flow test at the sprinkler system demand.

Installation

The Model PRV-1 Pressure Reducing Valve must be installed with the flow arrow located on the Diaphragm Cover pointing in the intended direction of flow. Installation dimensions are provided in Figures 5 and 6.

Before the PRV-1 is installed, pipe lines should be flushed of all chips, scale and foreign matter. Care must be exercised to assure that the trim is not damaged during installation. **Do Not Lift The Valve By Its Trim.**

NOTES

The inlet and outlet connections must be made based on the direction of flow arrow provided on the handhole cover. The valve cannot operate if connected backwards.

Do not alter the trim. Altering the trim may render the valve ineffective and impair the system operation.

Placing The Valve In Service

Steps 1 through 12 are to be performed when placing the Model PRV-1 Pressure Reducing Valve in service.

WARNING

Downstream pressure adjustment is only to be performed by experienced personnel who understand the impact of adjusting the downstream pressure and who take full responsibility of the readjustment from the factory setting. *The Pilot Valve is provided with a Tamper Cap, which upon removal for purposes of downstream adjustment will provide an indication that the PRV-1 may have been altered from the factory setting.*

Adjustment of the Needle Valve is factory set and must not be altered. *The Needle Valve is provided with a tamper indication, which upon removal for purposes of any adjustment will provide an indication that the PRV-1 may have been altered from the factory setting.*

NOTES

Per the requirements of NFPA 13, a means shall be provided downstream of the PRV-1 to simulate the sprinkler system demand. In the case of hose stations, the opening of a hose valve or multiple hose valves, as required, will be necessary to simulate hose stream demand.

For the purposes of the following in-

struction, the opening of a "flow test valve" simulates either the sprinkler demand or hose stream demand, as applicable. The sprinkler demand or hose stream demand must be at least 50 GPM (190 LPM) for 2 to 6 inch (DN50 to DN150) valves and at least 100 GPM (380 LPM) for 8 inch (DN200) valves.

There is no need to vent any trapped air from the Diaphragm Chamber.

Filling The System:

Step 1. Verify that downstream drain valves are closed and that there are no leaks.

Step 2. Partially open a valve or valves at the end of the system (e.g., an inspector's test connection on a wet pipe system) to allow trapped air to escape when filling the system.

Step 3. Slowly and partially open the water supply control valve feeding the PRV-1.

Step 4. After the system fills with water, close the valve or valves that had been partially opened in Step 2.

Step 5. Completely open the main water supply control valve feeding the PRV-1.

Downstream Pressure Adjustment:

Step 6. Remove the Tamper Cap from the Pilot Valve by first loosening its set screw and then unscrewing the Tamper Cap.

Step 7. Open the "flow test valve" to simulate either the desired sprinkler demand or hose stream demand.

NOTE

If surging flow occurs, attempt to bleed trapped air from the system via the inspector's test valve and any other valve that can vent trapped air.

Step 8. Loosen the locknut on the adjusting screw of the Pilot Valve.

Step 9. Turn the adjusting screw clockwise to increase outlet pressure or counterclockwise to decrease outlet pressure.

Step 10. After achieving the desired performance, tighten the locknut on the adjusting screw.

Step 11. Close the "flow test valve". Observe the outlet pressure gauge and compare to the required "set pressure". If the required "set pressure" is not achieved, repeat Step 8 and proceed accordingly.

Step 12. Replace the Tamper Cap and tighten its set screw.

The pressure reducing valve is now set for service.

NOTES

Due to the spring tolerance within the Pilot Valve, it may be necessary to alternate back and forth between residual and static conditions to achieve the desired "set pressure" for both residual and static conditions.

After any downstream pressure adjustment, the following items are to be recorded on a tag attached to the valve:

- Valve installation location
- Inlet static pressure
- Outlet static pressure
- Inlet residual pressure
- Outlet residual pressure
- Intended outlet flow

The tag is not to be removed until after the system has been accepted by the Authority Having Jurisdiction. It is recommended that the tag not be removed even after acceptance by the Authority Having Jurisdiction unless another means of record keeping is maintained.

Care and Maintenance

Inspection, testing, and maintenance must be performed in accordance with the requirements of the NFPA, and any impairment must be immediately corrected.

The owner is responsible for the inspection, testing, and maintenance of their fire protection system and devices in compliance with this document, as well as with the applicable standards of any authorities having jurisdiction. The installing contractor or product manufacturer should be contacted relative to any questions.

It is also recommended that automatic sprinkler systems be inspected, tested, and maintained by a qualified Inspection Service in accordance with local requirements and/or national codes.

NOTE

Before closing a fire protection system main control valve for maintenance work on the fire protection system that it controls, permission to shut down the affected fire protection systems must first be obtained from the proper authorities and all personnel who may be affected by this decision must be notified.

The Model PRV-1 Pressure Reducing Valve requires no lubrication, packing or preventative maintenance; however, replacement of the diaphragm every five years is recommended.

Flow Tests. Flow tests per NFPA are required every five years, at which point the outlet pressure is compared to previous tests. If necessary the PRV-1 can be readjusted following the Placing The Valve In Service section. If the desired pressure cannot be achieved, the Diaphragm and/or Pilot Valve should be replaced.

Diaphragm Replacement. Prior to replacing the Diaphragm, the PRV-1 must be taken out of service and completely drained. With reference to Figure 3, the Diaphragm Tab is oriented perpendicular to the outlet flow. When reinstalling the Diaphragm Cover, the Diaphragm Cover Fasteners **must be uniformly and securely tightened using a cross-draw sequence.** After tightening, double check to make certain that all of the Diaphragm Cover fasteners are securely tightened.

Pilot Valve Replacement. Prior to removing the Pilot Valve, the PRV-1 must be taken out of service and completely drained. When installing the replacement Pilot Valve, the trim components must be replaced exactly as they were. After reinstalling the Pilot Valve and before returning the PRV-1 into service, completely unscrew the Adjusting Stem of the replacement Pilot Valve so as to obtain a minimum outlet "set pressure". Then proceed to use the instructions under Placing The Valve In Service section to place the PRV-1 in service.

NOTES

The Pilot Valve is not field repairable. Attempting to repair the Pilot Valve may render the valve ineffective and impair the system operation.

Completely unscrewing the Adjusting Stem of the replacement Pilot Valve will help to avoid an accidental over pressurization of the system piping prior to achieving the desired "set pressure".

Limited Warranty

Products manufactured by Tyco Fire & Building Products (TFBP) are warranted solely to the original Buyer for ten (10) years against defects in material and workmanship when paid for and properly installed and maintained under normal use and service. This warranty will expire ten (10) years from date of shipment by TFBP. No warranty is given for products or components manufactured by companies not affiliated by ownership with TFBP or for products and components which have been subject to misuse, improper installation, corrosion, or which have not been installed, maintained, modified or repaired in accordance with applicable Standards of the National Fire Protection Association, and/or the standards of any other Authorities Having Jurisdiction. Materials found by TFBP to be defective shall be either repaired or replaced, at TFBP's sole option. TFBP neither assumes, nor authorizes any person to assume for it, any other obligation in connection with the sale of products or parts of products. TFBP shall not be responsible for sprinkler system design errors or inaccurate or incomplete information supplied by Buyer or Buyer's representatives.

In no event shall TFBP be liable, in contract, tort, strict liability or under any other legal theory, for incidental, indirect, special or consequential damages, including but not limited to labor charges, regardless of whether TFBP was informed about the possibility of such damages, and in no event shall TFBP's liability exceed an amount equal to the sales price.

The foregoing warranty is made in lieu of any and all other warranties, express or implied, including warranties of merchantability and fitness for a particular purpose.

This limited warranty sets forth the exclusive remedy for claims based on failure of or defect in products, materials or components, whether the claim is made in contract, tort, strict liability or any other legal theory.

This warranty will apply to the full extent permitted by law. The invalidity, in whole or part, of any portion of this warranty will not affect the remainder.

Thread x Thread End Connections							
Nominal Valve Sizes	Nominal Installation Dimensions in Inches and (mm)						Weight
	A	B	C	D	E	F	lbs. (kg)
2" (DN50)	7.51 (191)	1.49 (38)	7.32 (186)	6.41 (163)	8.18 (208)	2.36 (60)	15.2 (6,9)
3" (DN80)	11.14 (283)	1.77 (45)	8.19 (208)	7.48 (190)	9.25 (235)	3.93 (100)	30.6 (13,9)

Groove x Groove End Connections							
Nominal Valve Sizes	Nominal Installation Dimensions in Inches and (mm)						Weight
	A	B	C	D	E	F	lbs. (kg)
2" (DN50)	7.51 (191)	1.49 (38)	7.32 (186)	6.41 (163)	8.18 (208)	2.36 (60)	15.2 (6,9)
3" (DN80)	11.14 (283)	1.77 (45)	8.19 (208)	7.48 (190)	9.25 (235)	3.93 (100)	30.6 (13,9)
4" (DN100)	13.62 (346)	4.37 (111)	8.70 (221)	7.91 (201)	9.68 (246)	4.52 (115)	45.2 (20,5)
6" (DN150)	17.79 (452)	3.30 (84)	9.88 (251)	6.73 (171)	11.49 (292)	5.90 (150)	118.0 (53,5)

Flange x Flange End Connections							
Nominal Valve Sizes	Nominal Installation Dimensions in Inches and (mm)						Weight
	A	B	C	D	E	F	lbs. (kg)
3" (DN80)	11.14 (283)	3.93 (100)	8.19 (208)	7.48 (190)	9.25 (235)	3.93 (100)	46.3 (21,0)
4" (DN100)	12.00 (305)	2.24 (57)	8.70 (221)	7.91 (201)	9.68 (246)	4.52 (115)	65.0 (29,5)
6" (DN150)	15.98 (406)	5.59 (142)	9.88 (251)	6.73 (171)	11.49 (292)	5.90 (150)	118.0 (53,5)
8" (DN200)	18.50 (470)	6.69 (170)	11.14 (283)	7.16 (182)	12.55 (319)	6.96 (177)	166.5 (75,5)

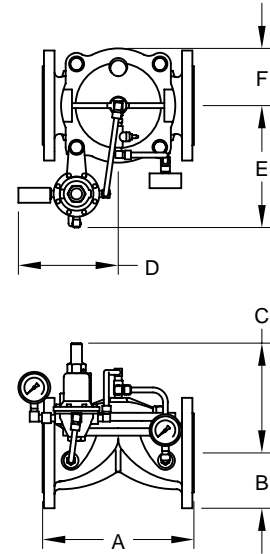

FIGURE 5
MODEL PRV-1 PRESSURE REDUCING VALVE
— GLOBE STYLE INSTALLATION DIMENSIONS —

Thread x Thread End Connections								
Nominal Valve Sizes	Nominal Installation Dimensions in Inches and (mm)							Weight
	A	B	C	D	E	F	G	lbs. (kg)
2" (DN50)	3.54 (90)	3.18 (81)	7.32 (186)	6.41 (163)	8.18 (208)	2.40 (61)	2.40 (61)	15.9 (7,2)
3" (DN80)	6.06 (154)	4.52 (115)	8.19 (208)	7.48 (190)	9.25 (235)	3.93 (100)	3.93 (100)	34.1 (15,5)

Groove x Groove End Connections								
Nominal Valve Sizes	Nominal Installation Dimensions in Inches and (mm)							Weight
	A	B	C	D	E	F	G	lbs. (kg)
2" (DN50)	3.54 (90)	3.18 (81)	7.32 (186)	6.41 (163)	8.18 (208)	2.40 (61)	2.40 (61)	15.9 (7,2)
3" (DN80)	6.06 (154)	4.52 (115)	8.19 (208)	7.48 (190)	9.25 (235)	3.93 (100)	3.93 (100)	34.1 (15,5)
4" (DN100)	6.33 (161)	4.56 (116)	8.70 (221)	7.91 (201)	9.68 (246)	4.52 (115)	4.52 (115)	44.0 (19,9)
6" (DN150)	8.89 (226)	6.69 (170)	9.88 (251)	6.73 (171)	11.49 (292)	5.90 (150)	5.90 (150)	89.3 (40,5)

Flange x Flange End Connections								
Nominal Valve Sizes	Nominal Installation Dimensions in Inches and (mm)							Weight
	A	B	C	D	E	F	G	lbs. (kg)
3" (DN80)	6.06 (154)	4.52 (115)	8.19 (208)	7.48 (190)	9.25 (235)	3.93 (100)	3.93 (100)	35.1 (15,9)
4" (DN100)	6.33 (161)	4.56 (116)	8.70 (221)	7.91 (201)	9.68 (246)	4.52 (115)	4.52 (115)	67.3 (30,5)
6" (DN150)	8.89 (226)	6.69 (170)	9.88 (251)	6.73 (171)	11.49 (292)	5.90 (150)	5.90 (150)	116.2 (52,7)

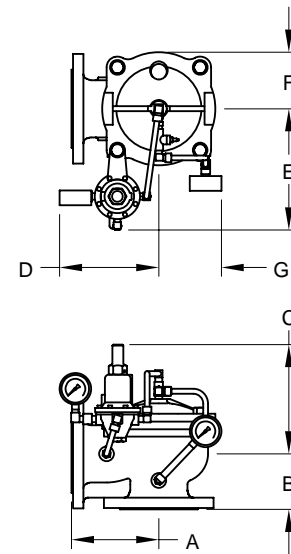
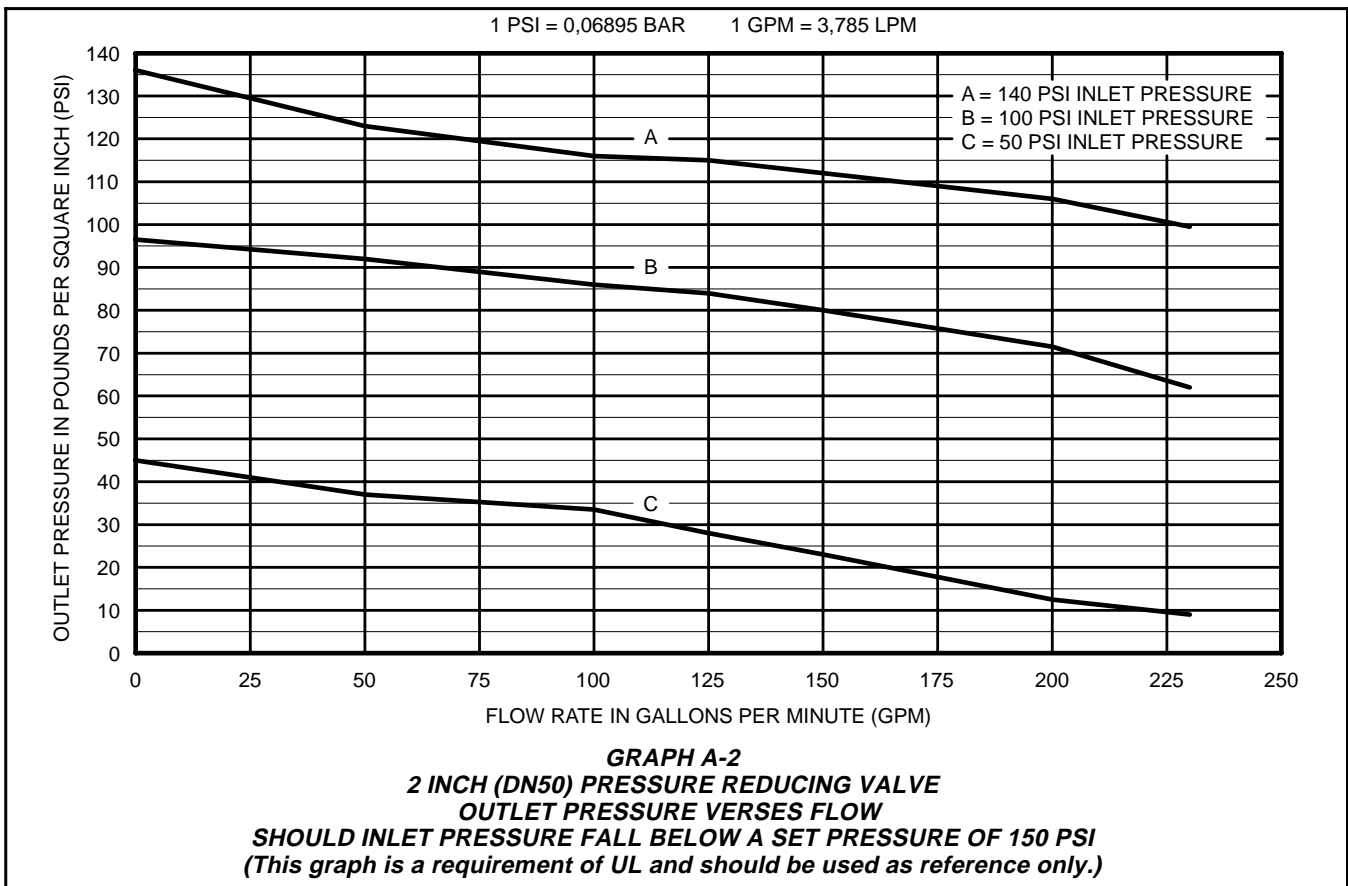
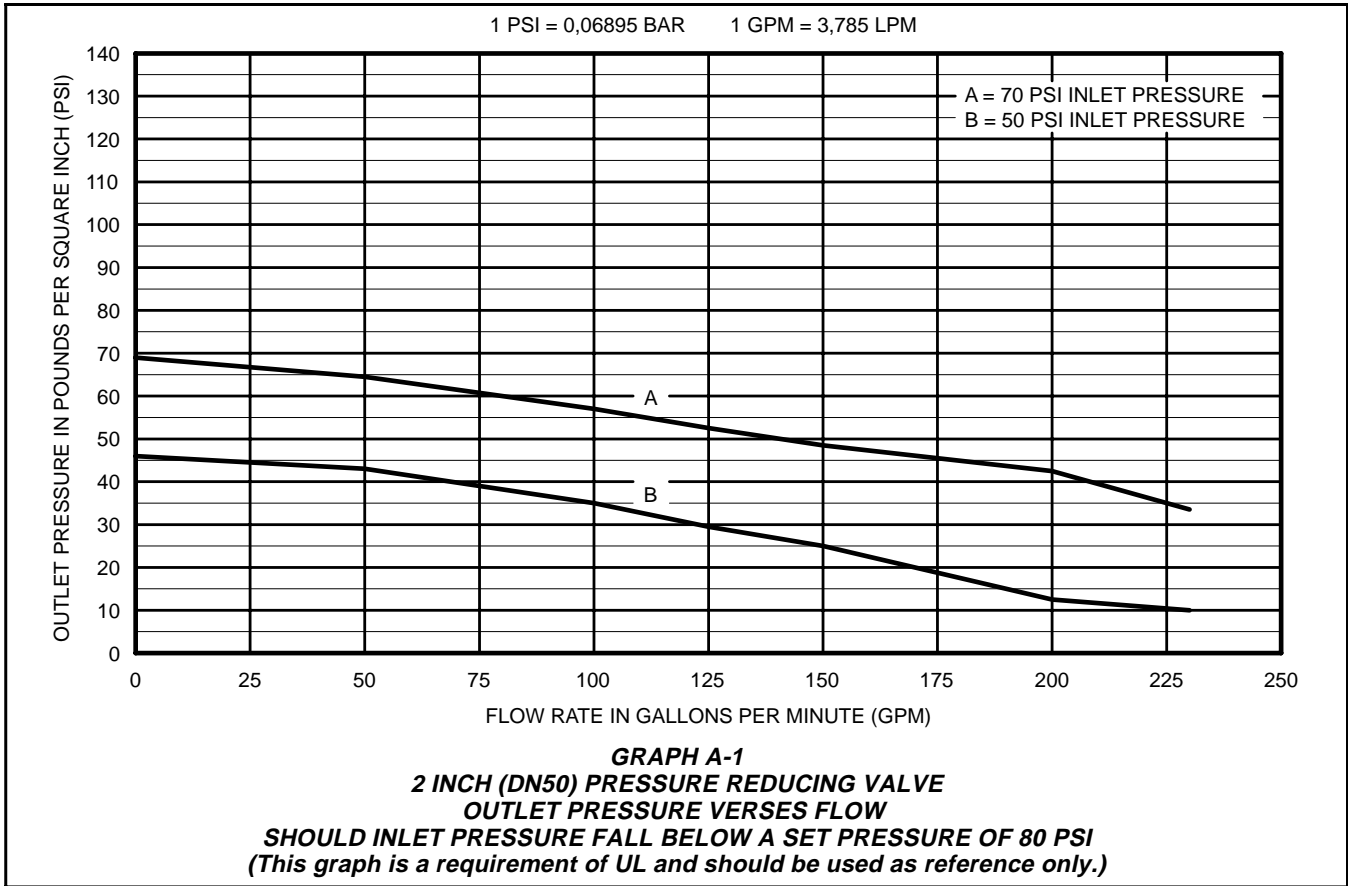
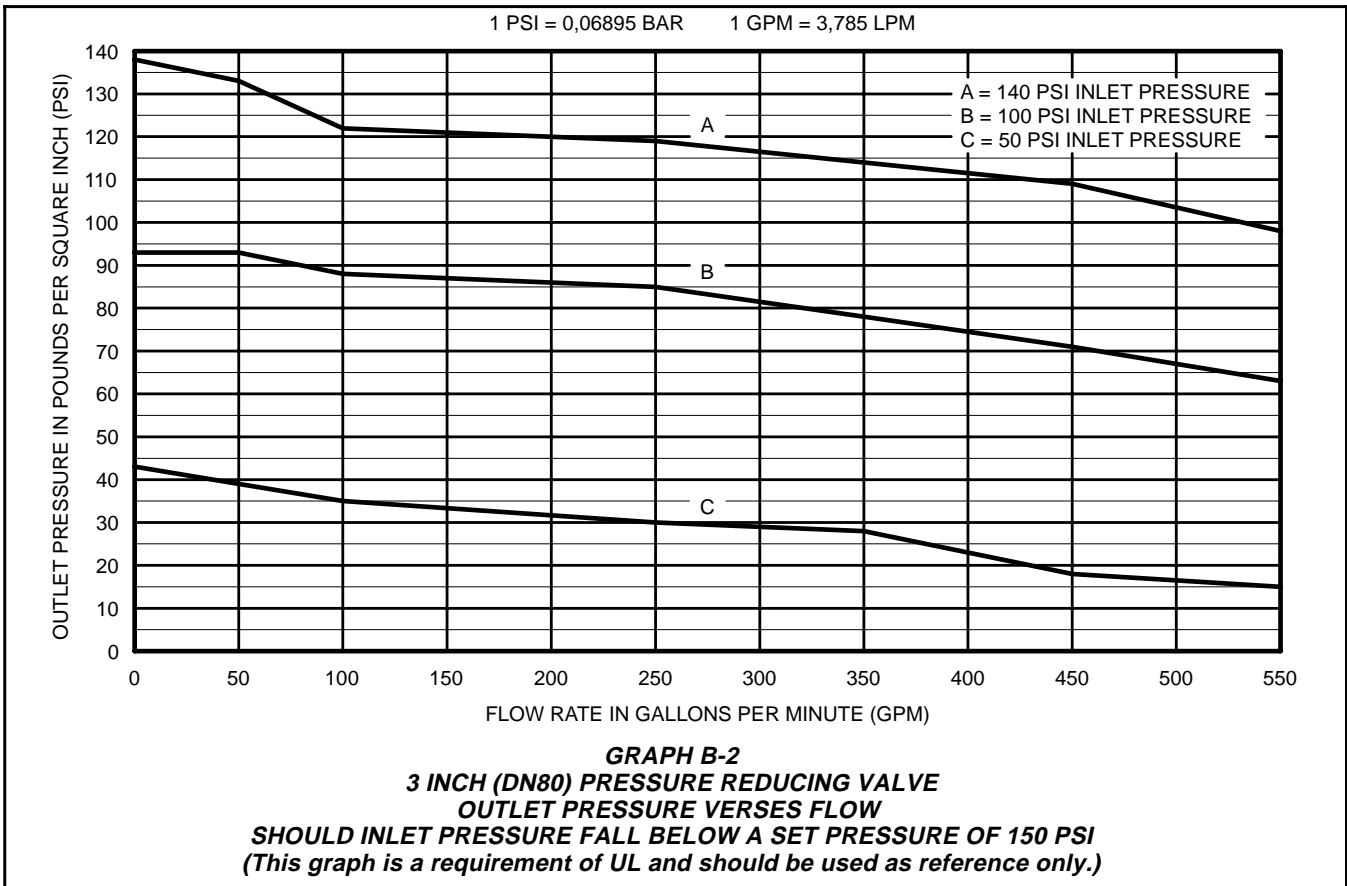
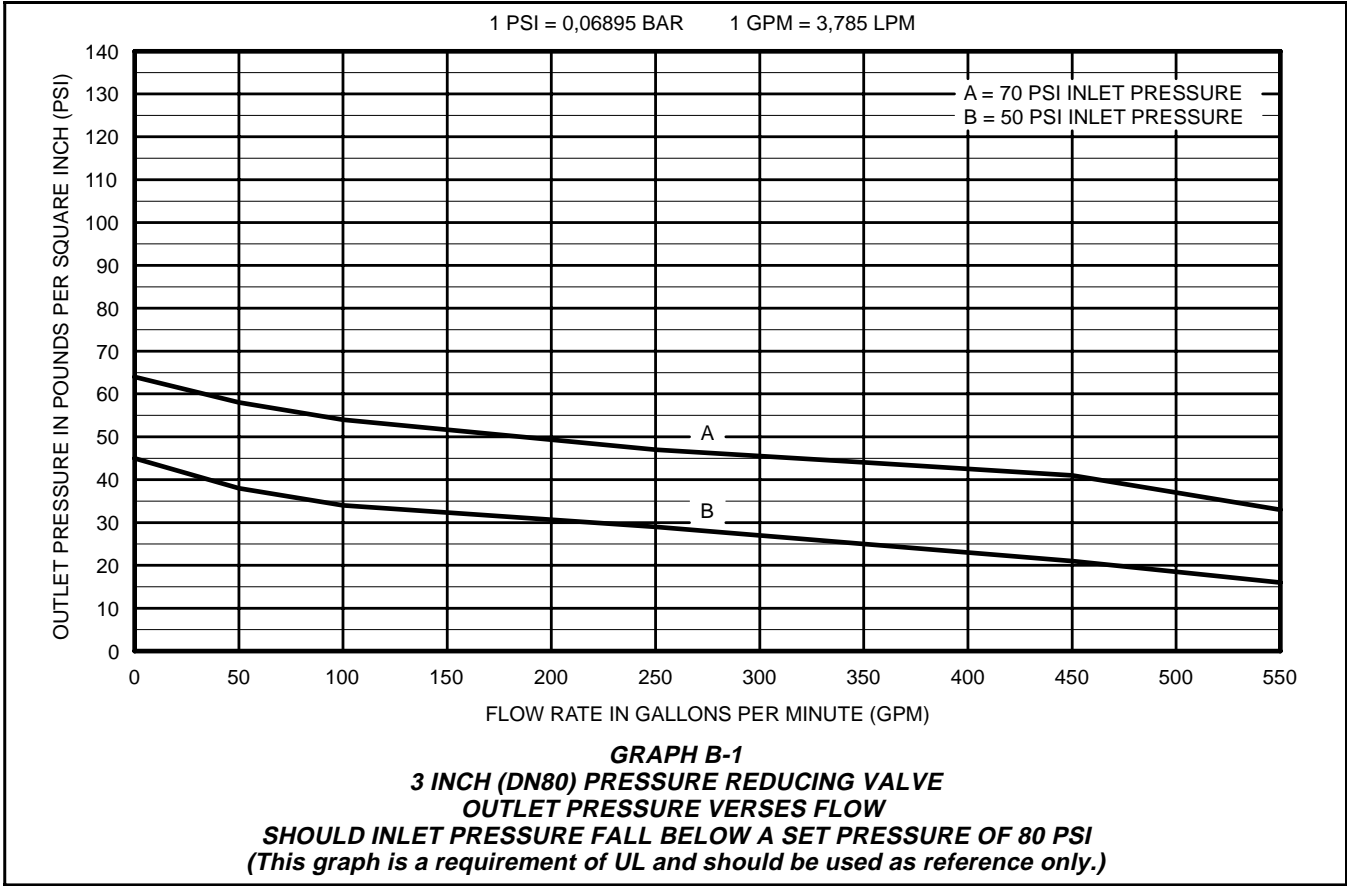
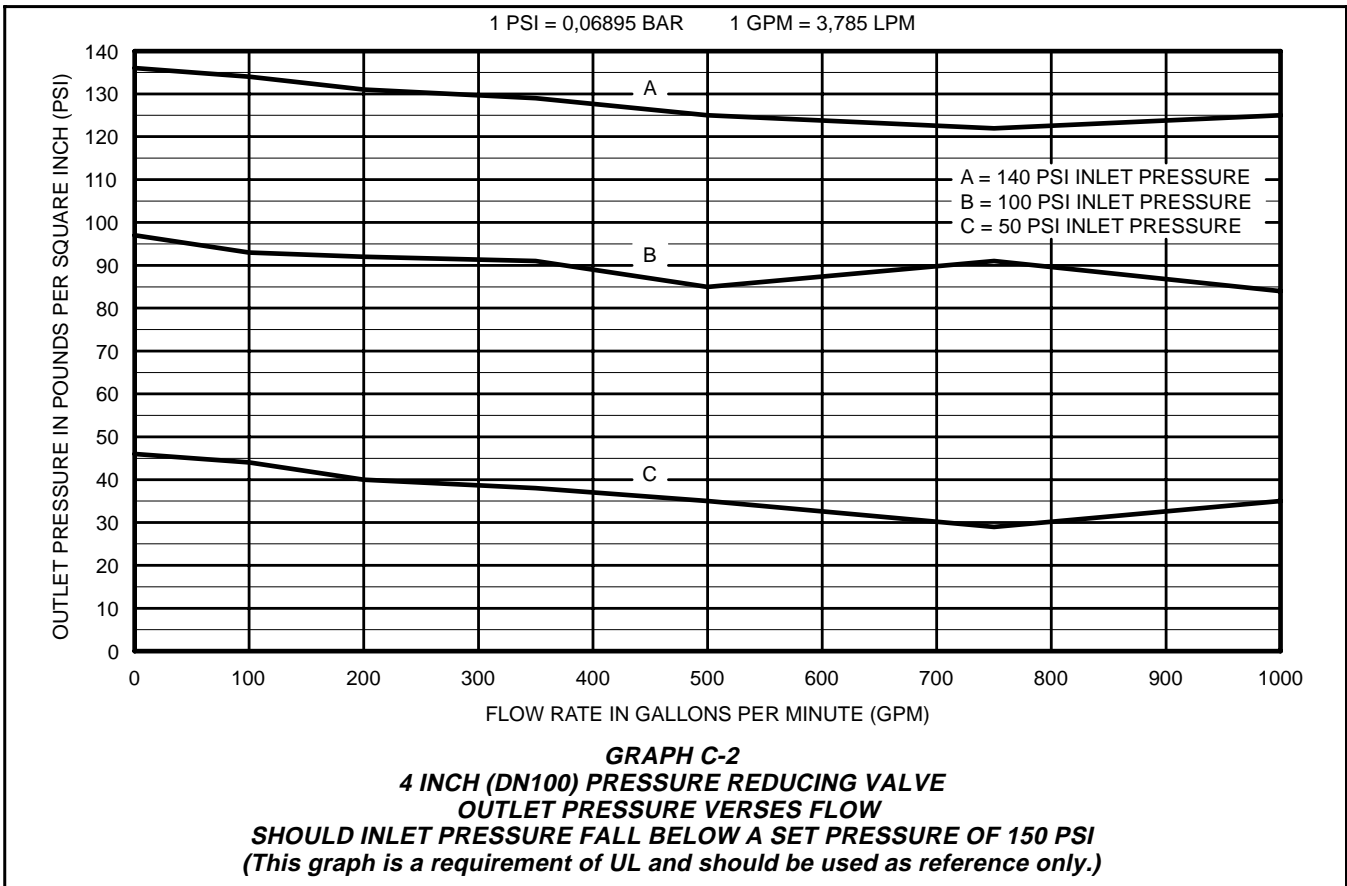
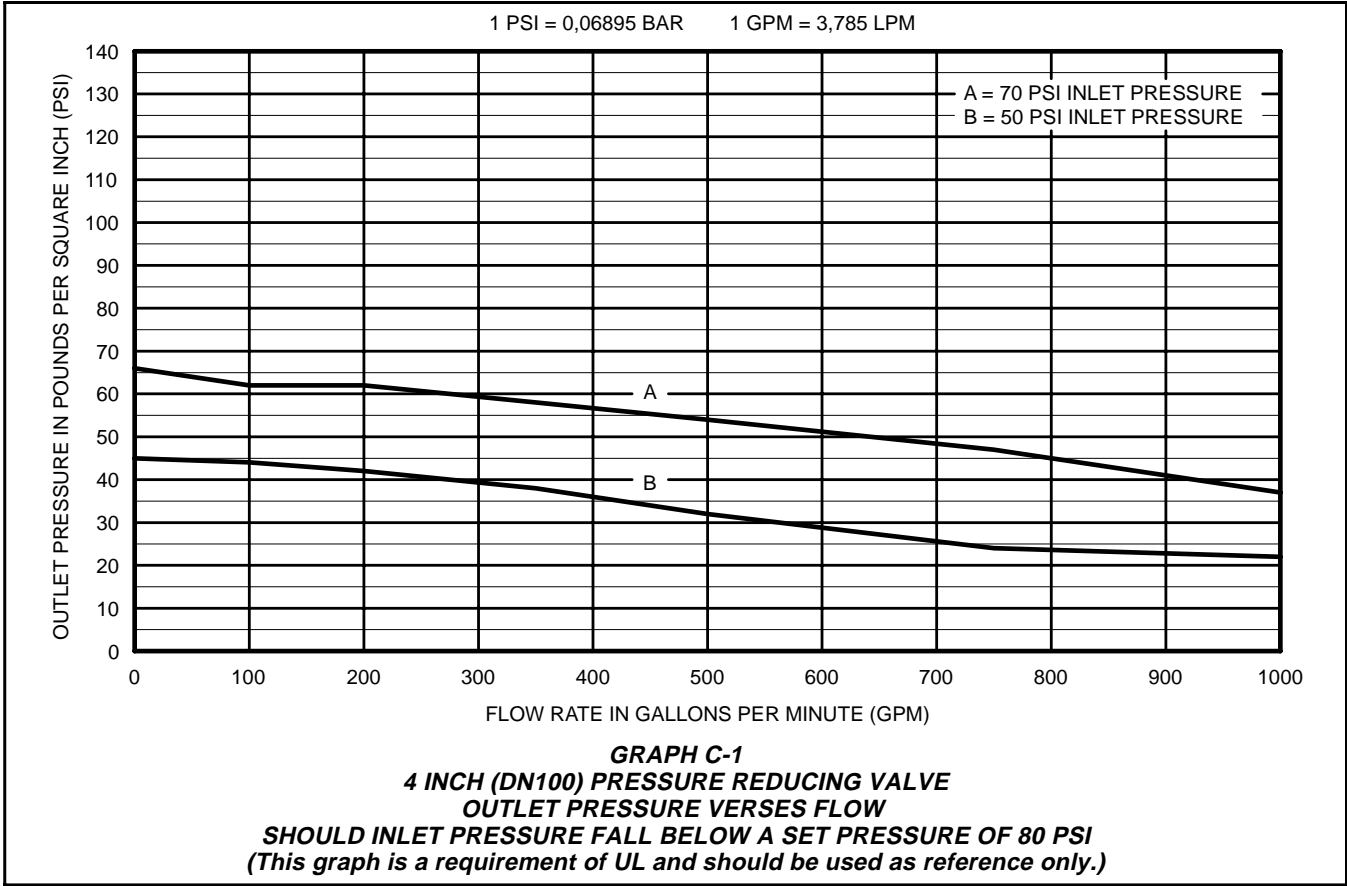
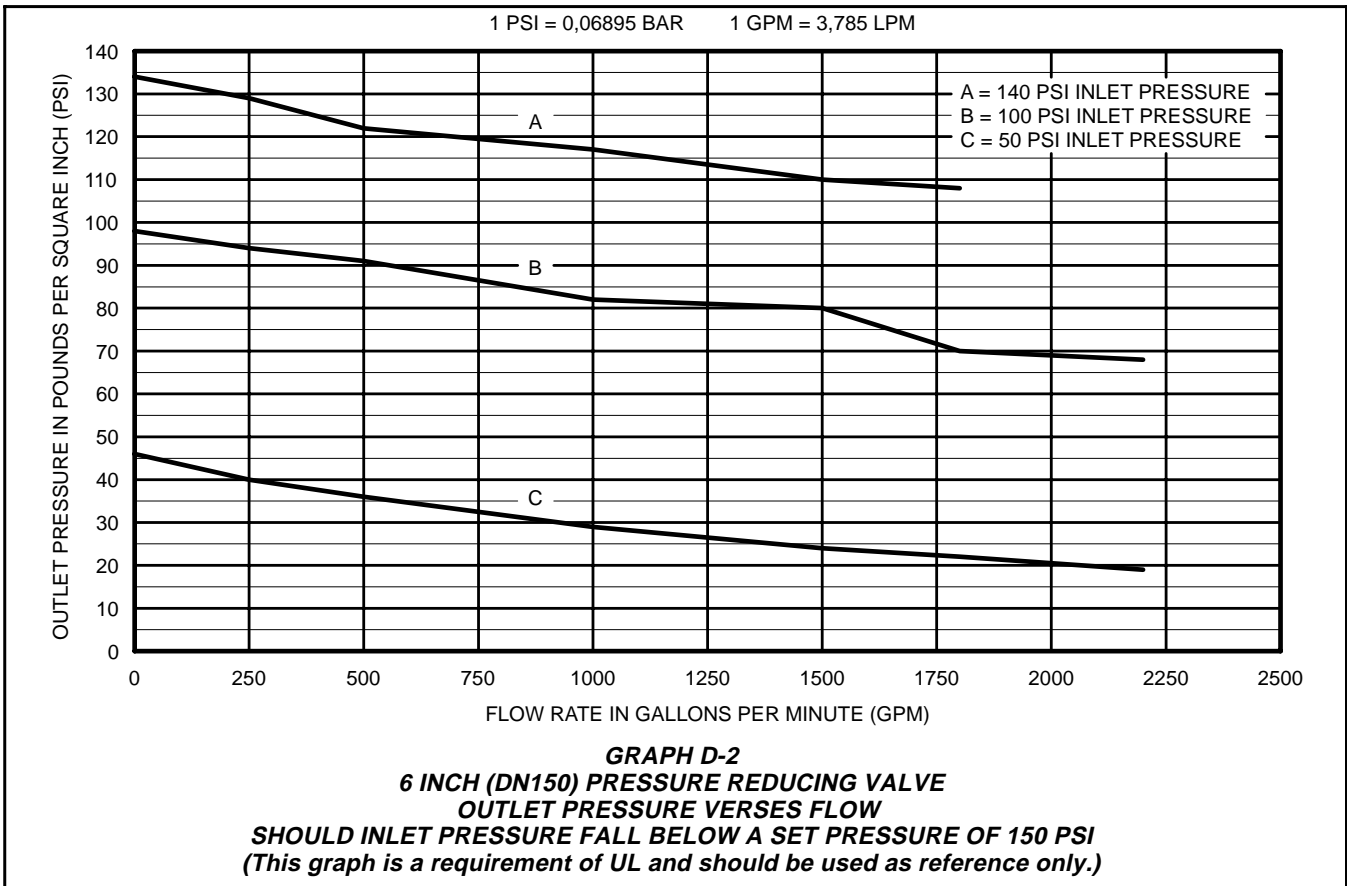
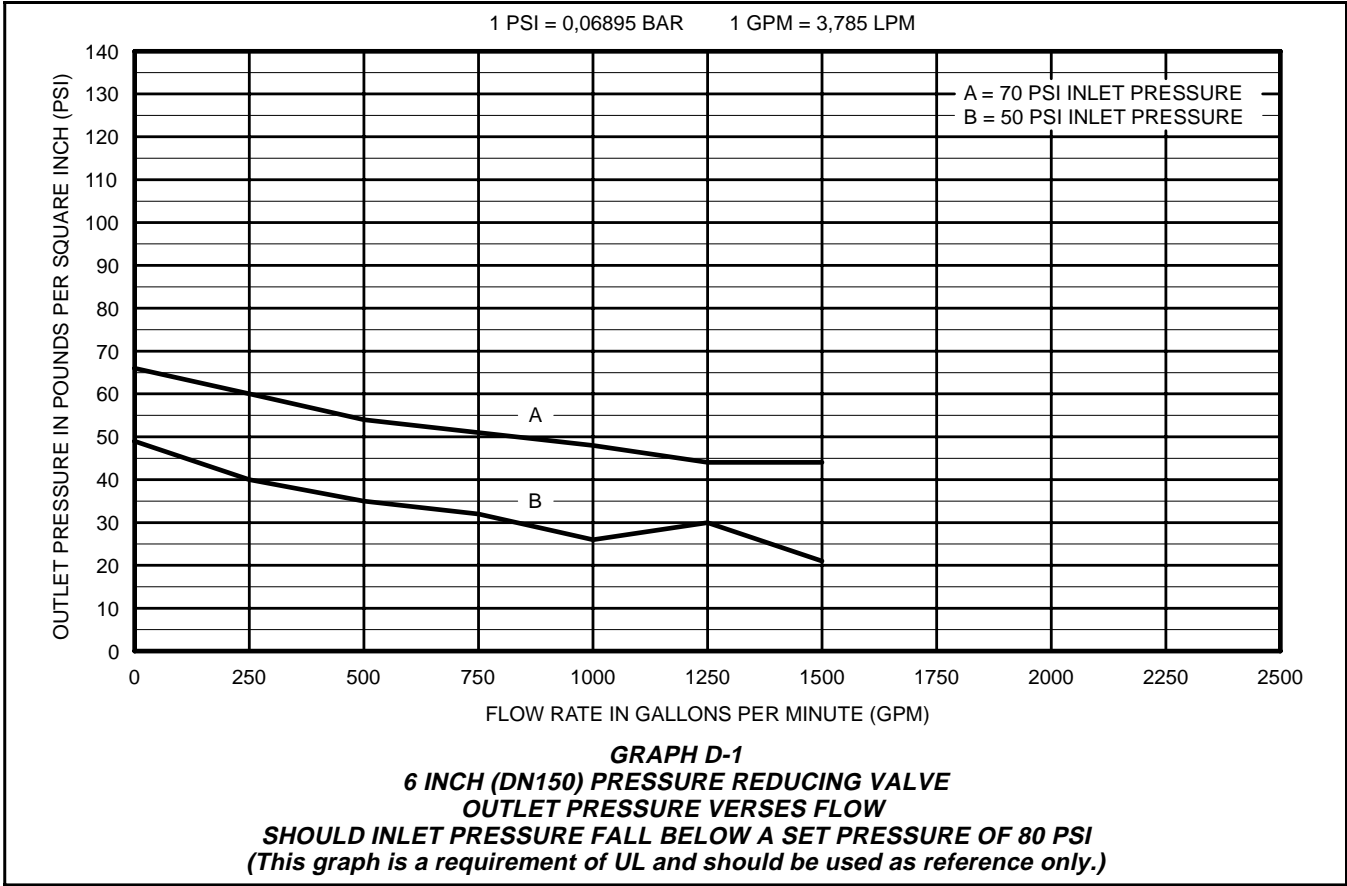

FIGURE 6
MODEL PRV-1 PRESSURE REDUCING VALVE
— ANGLE STYLE INSTALLATION DIMENSIONS —









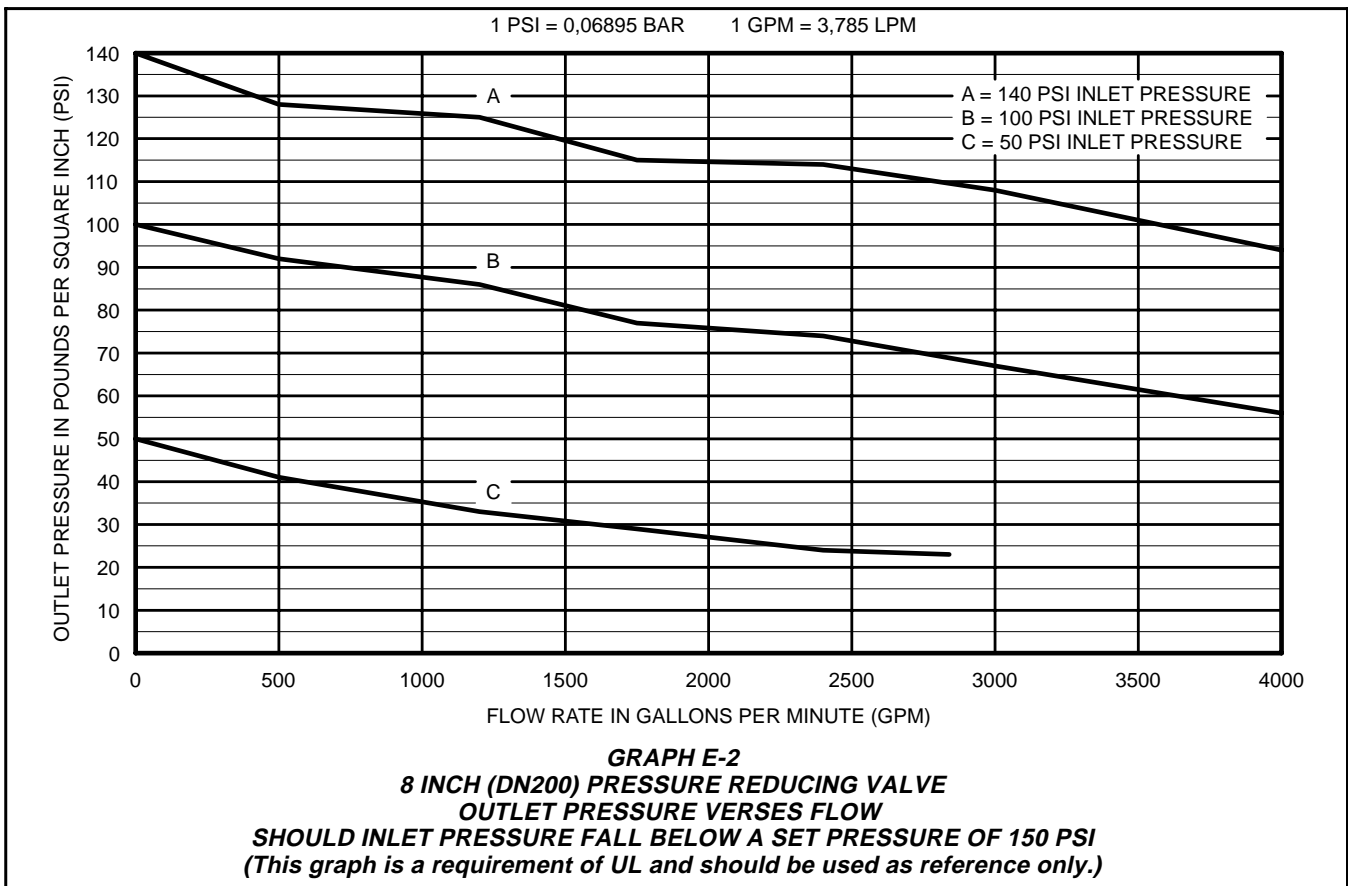
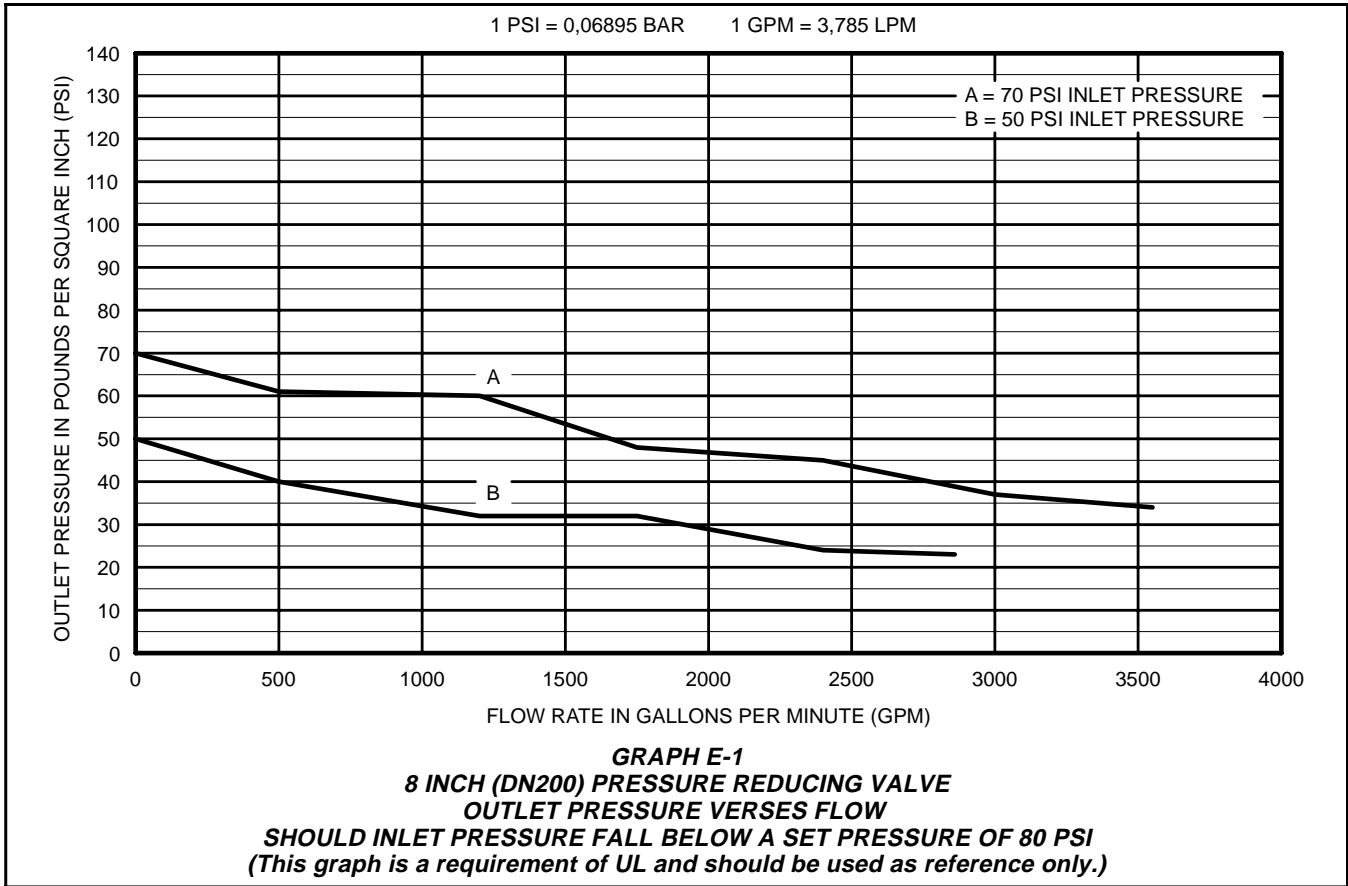

Ordering Procedure

North America

Pressure Reducing Valve:

Specify: Globe Type, (specify size), 125 psi Outlet "Set Pressure" with (T x T, G x G, or F x F) Connection, P/N (specify from below).

P/N's for GLOBE BODY STYLE AVAILABLE IN AMERICAS

2 Inch T x T NPT	P/N 52-570-8-060
2 Inch G x G 2.37 inch (60,3 mm) Groove O.D.....	P/N 52-570-8-920
3 Inch G x G 3.50 inch (88,9 mm) Groove O.D.	P/N 52-570-8-922
4 Inch G x G 4.50 inch (114,3 mm) Groove O.D.	P/N 52-570-8-923
4 Inch F x F ANSI Flange	P/N 52-570-8-023
6 Inch G x G 6.62 inch (168,3 mm) Groove O.D.	P/N 52-570-8-925
6 Inch F x F ANSI Flange.	P/N 52-570-8-025
8 Inch F x F ANSI Flange	P/N 52-570-8-026

Pressure Relief Valve:

Specify: 1/2 inch (DN15) Watts Regulator, Series 530C Pressure Relief Valve for use downstream of a PRV-1 being used for reducing pressure in sprinkler system, P/N 92-570-2-208.

Replacement Valve Parts:

Specify: (description) for use with (specify) size Model PRV-1 Pressure Reducing Valve, P/N (see Figure 3).

Ordering Procedure

South America, Central America & Eastern Hemisphere

Pressure Reducing Valve:

Specify: (Globe or Angle) Type, (specify size), 125 psi Outlet "Set Pressure" with (specify) Connection (and for flanged valves specify flange drilling), P/N (specify from complete listing on Page 16).

- Valve Type & Size
(Globe, 2, 3, 4, 6, or 8 Inch)
(Angle, 2, 3, 4, or 6 Inch)
 - 125 psi Outlet "Set Pressure" Pressure
 - Connection Type
(Threaded, Grooved, Flanged)
For threaded, specify NPT or ISO
For grooved, specify O.D. Pipe Size
 - 2 inch (DN50):
2.88 inch (60,3 mm) O.D.
 - 3 inch (DN80):
3.50 inch (88,9 mm) O.D.
 - 4 inch (DN100):
4.50 inch (114,3 mm) O.D.
 - 6 inch (DN150):
6.62 inch (168,3 mm) O.D. or
6.50 inch (165,1 mm) O.D.
 - 8 inch (DN200):
8.62 inch (219,1 mm) O.D.
- For flanged, specify flange drilling per
- ANSI B16-1 (Class 125)
 - ISO 7005-2 (PN16)
 - ISO 7005-2 (PN10),
8 inch valve only
 - JIS B2210 (10K)
 - AS 2129 (Table E)

NOTES

Refer to Table A for flange drilling dimensional specifications.

Pressure Relief Valve:

Specify: 1/2 inch (DN15) Watts Regulator, Series 530C Pressure Relief Valve for use downstream of a PRV-1 being used for reducing pressure in sprinkler system, P/N 92-570-2-208.

Replacement Valve Parts:

Specify: (description) for use with (specify) size Model PRV-1 Pressure Reducing Valve, P/N (see Figure 3).

P/N's for GLOBE BODY STYLE

2 Inch T x T NPT	P/N 52-570-8-060
2 Inch T x T ISO	P/N 52-570-8-160
2 Inch G x G 2.37 inch (60,3 mm) Groove O.D.....	P/N 52-570-8-920
3 Inch T x T NPT	P/N 52-570-8-062
3 Inch T x T ISO	P/N 52-570-8-162
3 Inch G x G 3.50 inch (88,9 mm) Groove O.D.	P/N 52-570-8-922
3 Inch F x F ANSI Flange	P/N 52-570-8-022
3 Inch F x F ISO (PN16) Flange....	P/N 52-570-8-112
3 Inch F x F JIS Flange.....	P/N 52-570-8-722
3 Inch F x F AS Flange	P/N 52-570-8-522
4 Inch G x G 4.50 inch (114,3 mm) Groove O.D.	P/N 52-570-8-923
4 Inch F x F ANSI Flange	P/N 52-570-8-023
4 Inch F x F ISO (PN16) Flange....	P/N 52-570-8-113
4 Inch F x F JIS Flange.....	P/N 52-570-8-723
4 Inch F x F AS Flange	P/N 52-570-8-523
6 Inch G x G 6.62 inch (168,3 mm) Groove O.D.	P/N 52-570-8-925
6 Inch G x G 6.50 inch (165,1 mm) Groove O.D.	P/N 52-570-8-945
6 Inch F x F ANSI Flange	P/N 52-570-8-025
6 Inch F x F ISO (PN16) Flange....	P/N 52-570-8-115
6 Inch F x F JIS Flange.....	P/N 52-570-8-725
6 Inch F x F AS Flange	P/N 52-570-8-525
8 Inch F x F ANSI Flange	P/N 52-570-8-026
8 Inch F x F ISO (PN10) Flange....	P/N 52-570-8-116
8 Inch F x F ISO (PN16) Flange....	P/N 52-570-8-126
8 Inch F x F JIS Flange.....	P/N 52-570-8-726
8 Inch F x F AS Flange	P/N 52-570-8-526

P/N's for ANGLE BODY STYLE

2 Inch T x T NPT	P/N 52-571-8-060
2 Inch T x T ISO	P/N 52-571-8-160
2 Inch G x G 2.37 inch (60,3 mm) Groove O.D.	P/N 52-571-8-920
3 Inch T x T NPT	P/N 52-571-8-062
3 Inch T x T ISO	P/N 52-571-8-162
3 Inch G x G 3.50 inch (88,9 mm) Groove O.D.	P/N 52-571-8-922
3 Inch F x F ANSI Flange.....	P/N 52-571-8-022
3 Inch F x F ISO (PN16) Flange ...	P/N 52-571-8-112
3 Inch F x F JIS Flange	P/N 52-571-8-722
3 Inch F x F AS Flange	P/N 52-571-8-522
4 Inch G x G 4.50 inch (114,3 mm) Groove O.D.	P/N 52-571-8-923
4 Inch F x F ANSI Flange	P/N 52-571-8-023
4 Inch F x F ISO (PN16) Flange ...	P/N 52-571-8-113
4 Inch F x F JIS Flange	P/N 52-571-8-723
4 Inch F x F AS Flange.....	P/N 52-571-8-523
6 Inch G x G 6.62 inch (168,3 mm) Groove O.D.	P/N 52-571-8-925
6 Inch G x G 6.50 inch (165,1 mm) Groove O.D.	P/N 52-571-8-945
6 Inch F x F ANSI Flange	P/N 52-571-8-025
6 Inch F x F ISO (PN16) Flange ...	P/N 52-571-8-115
6 Inch F x F JIS Flange	P/N 52-571-8-725
6 Inch F x F AS Flange.....	P/N 52-571-8-525