

INSPECTOR TEST VALVE

Model: 614

Features

- Use at the End of each Branch Pipe to Simulate Flowrate of One (1) Sprinkler Head Activation
- Positive Positioning of Handle for Off, Test & Drain positions

Sizes : 25mm[1"] & 32mm[1¼"]

Connection : NPT

Orifice : 15mm (½") Nominal

How to Order : Model, Size

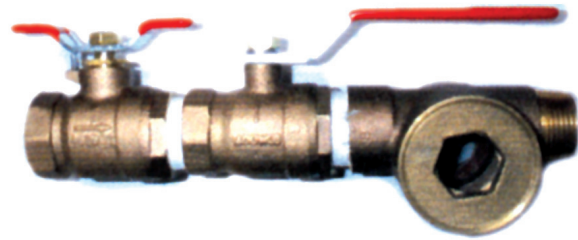

Dimension in inch/mm

NORMAL SIZE	IN	1	1¼
A	mm	261.5	275
D	mm	25.4	31.75
H	mm	60	60
L	mm	130	130
I	mm	61	64
J	mm	110	110
K	mm	22.5	13
WEIGHT	kg	1.87	2.38

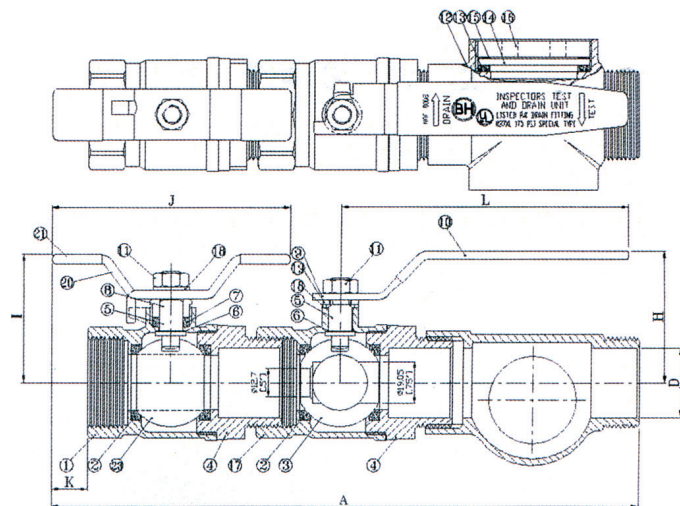

Part List

Part No	Description	Material	Part No	Description	Material
1	Body	ASTM B584 C84400	12	BRASS SIGHT GAUGE	ASTM B584 C85700
2	BODY SEAT	Teflon	13	PACKING	NBR
3	BALL	ASTM B16 C36000	14	CLEAR PLATE	Acrylic
4	BODY INSERT	ASTM B584 C84400	15	FIBER WASHER	Vulcanized Fiber
5	STEM	ASTM B16 C36000	16	FIX COLLAR	ASTM B584 C85700
6	STEM SEAT	Teflon	17	BALL VALVE	ASTM B584 C84400
7	BONNET SEAT	Teflon	18	SPRING	Stainless Steel
8	GLAND	ASTM B16 C36000	19	WASHER	Teflon
9	HANDLE	Carbon Steel	20	OVAL HANDLE	Carbon Steel
10	HANDLE SLEEVE	Vinyl	21	HANDLE SLEEVE	Vinyl



[Registered under Ban Chang]