

# Inline Inductor

MI-25, 25/40, 40, 50, 65

(replaces datasheets 1004/17-18)

## General description

The function of the stationary inline inductor is to inject foam liquid into a water stream. The inductor is designed to handle high back pressures, extending the distance from injection point to foam applicator.

## Application description

An inline inductor is used in fixed installations, to inject low/medium and high expansion foam concentrates into water flow lines, for deluge and fire monitor installations.

## Product features

- Corrosion resistant with brass body construction
- Factory calibrated to any flow and pressure within the range
- Integrated suction check valve
- MI series ranges from 100 l/min at 5.0 bar to 1450 l/min at 16 bar inlet pressure
- Suction height up to 3.5 m
- Foam induction up to 6%
- Installation in horizontal or vertical plane
- Hot-dipped galvanized steel flanges

## Installation

- Water inlet/outlet: to fit DIN PN16 or ANSI 150lbs or screw threaded BSP
- Foam inlet check valve: screw threaded BSP female

## Optional components

- Foam inlet ball valve: screw threaded BSP female
- Optional bronze flanges
- Foam concentrate suction hose
- Inductors available in alternative materials - please enquire for further details

Performance Data	
MI-25 and MI-25/40	
Water capacity at 16 bar	Max. 400 l/min
Working pressure	Max. 16 bar
Proportioning	Max. 6%
Pressure drop	Approx. 35% of inlet pressure



MI-25 / 40

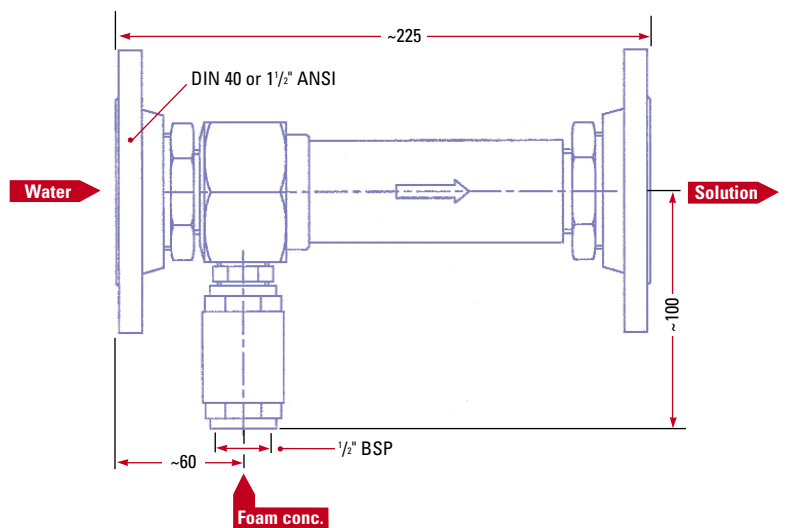

## Listings and approvals

- Det Norske Veritas DNV
- Russian Maritime Register of Shipping
- ISCIR
- American Bureau of Shipping (ABS)

Technical Data		
	MI-25	MI-25/40
Connection: Water	Male 1" BSP	40 DIN PN 16 or 1 1/2" ANSI 150 lbs
Connection: Foam	Female 1/2" BSP	Female 1/2" BSP
Weight	2.6 kgs / 5.75 lbs	7 kg / 15.5 lbs
Material	Body	Brass
	Flange	Galvanized steel
Included	Foam conc. check valve	Foam conc. check valve
Optional	Foam conc. suction hose	Foam conc. suction hose

1 bar = 0,1 MPa = 14,5 psi



www.skum.com

tyco Fire Suppression & Building Products

# Inline Inductor

MI-25, 25/40, 40, 50, 65

(replaces datasheets 1004/17-18)



## MI-50 / 65

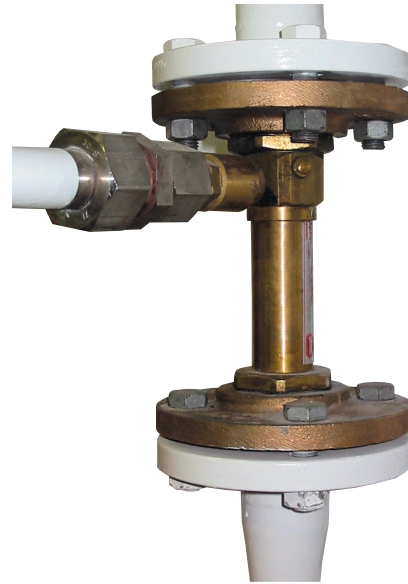
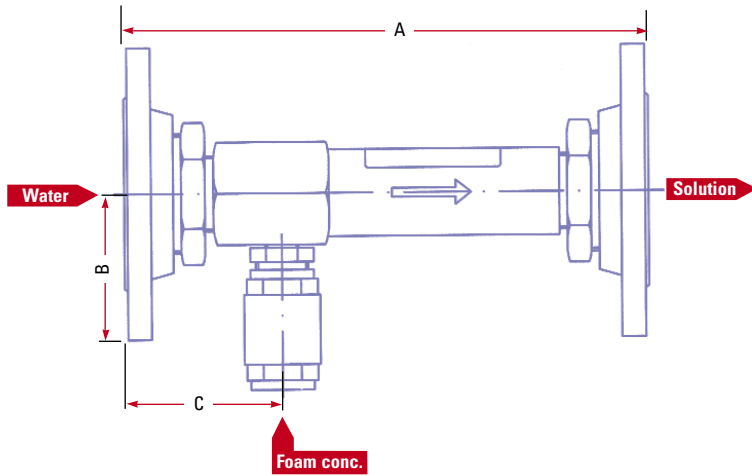

### Order information - please specify:

1. Size of inductor
2. Flange type: DIN or ANSI
3. Water and foam capacity and inlet pressure
4. Type of foam concentrate (see matrix below) and mixing rate

### Performance Data

#### MI-40, MI-50 and MI-65

Water capacity at 16 bar	Max. 1450 l/min
Working pressure	Max. 16 bar
Proportioning	Max. 6%
Pressure drop	Approx. 35% of inlet pressure

### Technical Data

	MI-40	MI-50	MI-65
Connection: Water	Female 1 1/2"	50 DIN PN 16 or 2" ANSI 150 lbs	65 DIN PN 16 or 2 1/2" ANSI 150 lbs
Connection: Foam conc.	Female 1" BSP	Female 1" BSP	Female 1" BSP
Weight	5.5 kg	10.5 kg	13 kg
Material	Body	Brass	Brass
		Flange	Galvanized steel
Dimensions approx:	A	218 mm	330 mm
	B	123 mm	123 mm
	C	43 mm	100 mm
Included		Foam conc. check valve	
Optional		Foam conc. suction hose	

1 bar = 0,1 MPa = 14,5 psi

### Capacity Areas for Inline Inductors

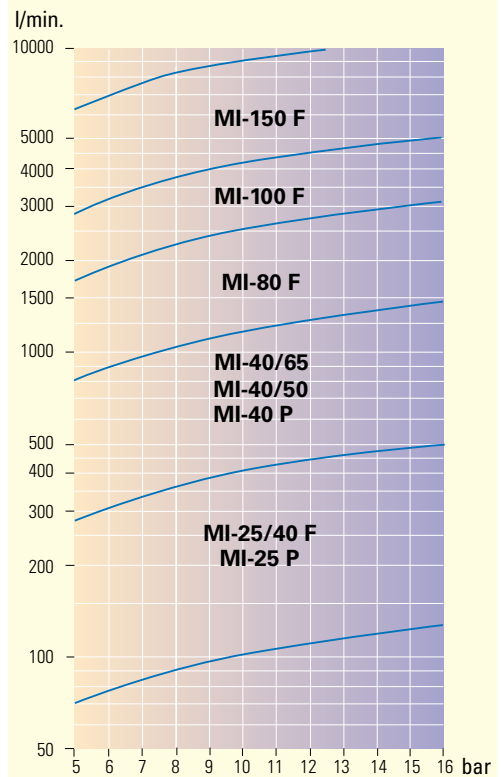

www.skum.com

tyco / Fire Suppression & Building Products