

(replaces datasheets 1011/131-132)

### General description

The FJM-80 monitor range offers portable fog/jet solution for foam/water discharge with exceptional performance characteristics. The monitor can be equipped with various types of nozzles.

The monitor bodies are constructed from stainless steel, keeping weight to a minimum whilst ensuring durability and reliability.

### Application description

The portable FJM range is used for fast response to fire incidents involving flammable liquid spills and vapour suppression, where the FJM 80 is able to deliver an effective fire fighting solution. The FJM is designed to deliver an optimised jet stream or fog pattern of water or foam.

### Product features

- Wide capacity range
- Adjustable flow and pattern
- Compact, balanced design
- Low weight
- Easily manoeuvrable due to low friction bearings
- Long throw length
- Corrosion resistant materials used in construction
- Maximum working pressure 8 bar



### Optional components

- Dual connection
- Automatic oscillation
- Built-in foam inducing nozzle

#### Performance Data

##### FJM-80 P

Water capacity	Up to 3,000 l/min
Rotation	220 degrees
Elevation	+30 to +80 degrees (normal safety)
Inlet connection	Dual 2 1/2" or single 2 1/2" or 3" BSP (must specify)
Material	Stainless steel and bronze
Surface treatment	Primer and red 2-component paint
Net weight, approx.	11 kg / 24 lbs
Nozzle	Manually adjustable from jet to fog
Slide bearings	Water balanced for rotation and elevation

Note: The nozzle can be easily adjusted on site for any specified capacity and pressure within its working range, according to separate adjustment table.

1 bar = 0,1 MPa = 14,5 psi

$$\text{Reaction force (N)} = 0.233 \times Q \text{ (l/min)} \times \sqrt{p \text{ (bar)}}$$

#### FJM-80 P

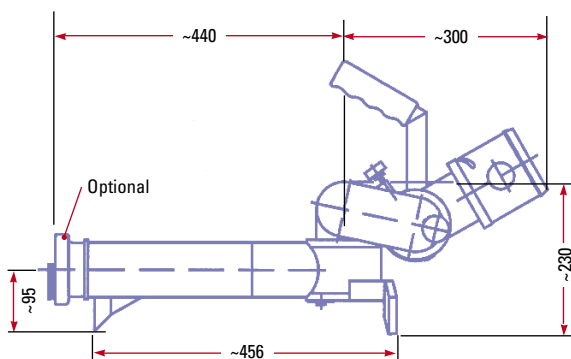

Stored: 650 x 500 x H 400

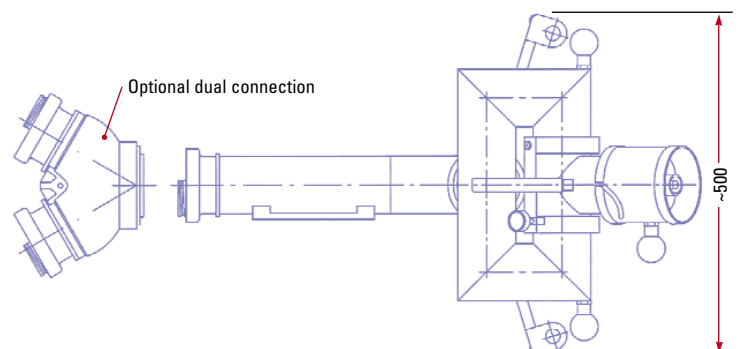

# Fog / Jet Monitor - Portable

FJM-P

(replaces datasheets 1011/131-132)

## Performance Data

### FJM-80 P0

Water capacity	Up to 3,000 l/min
Oscillating	60 degrees (disconn. 220 degrees)
Elevation	+30 to +80 degrees (normal safety)
Inlet connection	Dual 2 1/2" or single 1 1/2" or 3" BSP (must specify)
Material	Stainless steel and bronze
Surface treatment	Primer and red 2-component paint
Net weight, approx.	14 kg / 31 lbs
Nozzle	Manually adjustable from jet to fog
Slide bearings	Water balanced for rotation and elevation

Optional	Built in pressure gauge
	Automatic nozzle

Note: The nozzle can be easily adjusted on site for any specified capacity and pressure within its working range, according to separate adjustment table.

1 bar = 0,1 MPa = 14,5 psi



$$\text{Reaction force (N)} = 0.233 \times Q \text{ (l/min)} \times \sqrt{p \text{ (bar)}}$$

## FJM-80 P O

