

Bladder Tank Proportioner TP and TPW

(replaces datasheets 1010/21 and 22)

General description

Skum TP and TPW proportioners guarantee accurate foam proportioning over a wide range of flow and pressure conditions; manufactured in bronze, they are suitable for maintenance-free installation in a wide range of industrial and marine environments.



Application description

The TP proportioner is used in conjunction with bladder tanks to supply accurate foam delivery to fire monitors and deluge systems. The TP / TPW is used in combination with the Skum bladder tank, MTB.

Product features

- Easily adjustable foam regulating nozzle
- Accurate proportioning over the range
- Maintenance free construction
- Compact design



TP-100/50

Installation

- Water: Wafer mounted between flanges (see table)
- Foam inlet: Flanged to fit DIN PN16 or ANSI 150 lbs or threaded BSP

Listings and approvals

- Det Norske Veritas (DNV)
- Factory Mutual approval for: TP-100/50; 150/50; 200/80
- RINA (TP-100/50)
- Russian Maritime Register of Shipping

Order information - please specify:

1. Size
2. Connection DIN or ANSI
3. Foam mixing rate % (optional)

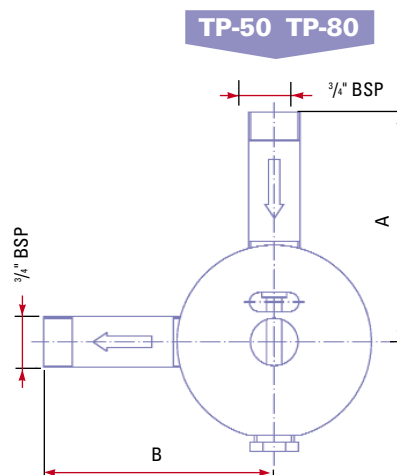

Performance Data TP Proportioners									
Type	Connection		Capacity				Weight		Proportioner k-factor
			Min.		Max.		kg	lbs	
	Foam/Water	Water	l/min	USGPM	l/min	USGPM			
TP-50/20	3/4" BSP	50 / 2"	125	33	800	211	5	11	300
TP-80/20	3/4" BSP	80 / 3"	300	79	2,000	528	9	20	1,010
TP-100/50	50 / 2"	100 / 4"	770	203	4,900	1,295	20	44	4,040
TP-150/50	50 / 2"	150 / 6"	1,500	396	9,800	2,589	25	55	7,970
TP-200/80	80 / 3"	200 / 8"	2,875	760	21,100	5,575	43	95	17,255
TP-250/80	80 / 3"	250 / 10"	5,100	1,347	33,100	8,745	51	112	27,060



Order information - please specify:

1. Size
2. Connection DIN or ANSI
3. Foam mixing rate % (optional)



TP / TPW-100, 150, 200, 250

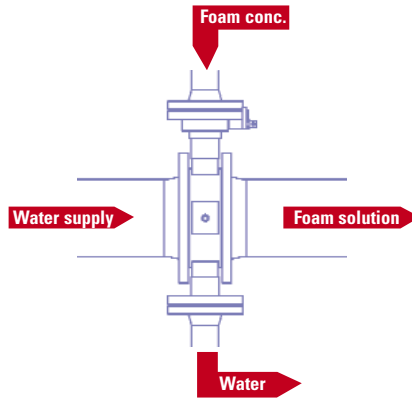
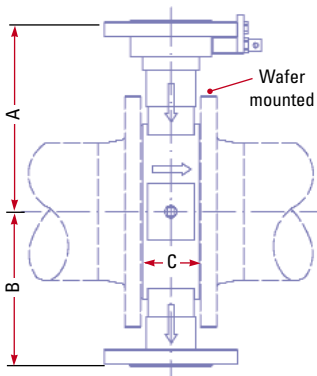

Dimensions TP and TPW

TP	TPW	A mm	B mm	C mm
TP-50/20		125	125	37
TP-80/20		140	140	37
TP-100/50	TPW-100/50	209	173	70
TP-150/50	TPW-150/50	241	198	70
TP-200/80	TPW-200/80	291	243	82
TP-250/80	TPW-250/80	323	276	82

Performance Data TPW Proportioners

Type	Connection		Capacity				Weight		Proportioner k-factor
			Min.		Max.		kg	lbs	
	Foam/Water	Water	l/min	USGPM	l/min	USGPM			
TPW-100/50	50 / 2"	100 / 4"	75	20	2,500	661	20	44	2,040
TPW-150/50	50 / 2"	150 / 6"	100	26	5,600	1,480	26	57	4,585
TPW-200/80	80 / 3"	200 / 8"	125	33	10,600	2,801	44	97	8,660
TPW-250/80	80 / 3"	250 / 10"	150	40	16,100	4,254	52	114	13,115

